

Sacrificial Anode for HR Pump

Zinc sacrificial anode for corrosion protection of HR pump ends

USE / PURPOSE

The LORENTZ Sacrificial Anode is designed for use with LORENTZ pump ends. Where solar pump ends operate in aggressive water conditions acidic water can attacks the passive layer of the high quality-steel pump end. This corrosion reduces the life time of the product. The LORENTZ Sacrificial Anode protects the pump system from this type of corrosion and extends the pump life

ORDER INFORMATION

- **Item no.:** 19-002621 **Product name:** Anode, Sacrificial Zink Anode, Di42mm
- **Item no.:** 19-002622 **Product name:** Anode, Sacrificial Zink Anode, Di48mm

FEATURES

- Simple and cost effective part to protect the pump end from corrosion
- Designed for HR pump ends



TECHNICAL DATA

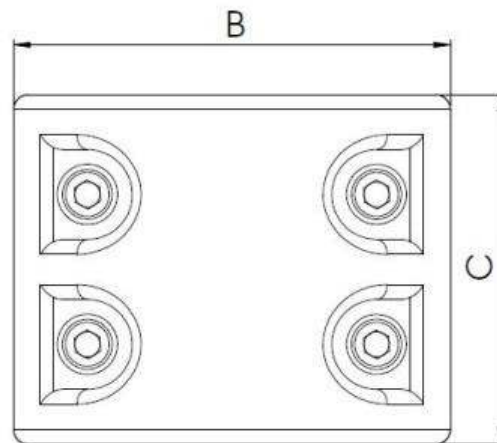
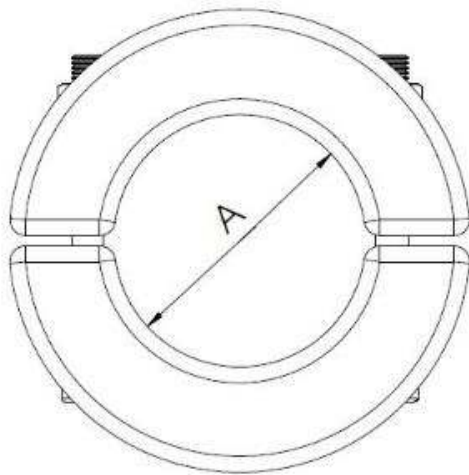

	A	B	C	Weight	Surface	Item no.
HR03/04/05	48 mm 1,89 in	88 mm 3,46 in	70 mm 2,76 in	1,76 kg 3,88 lbs	59100 mm ² 91,61 in ²	19-002622
HR07/10/14/23/32	42 mm 1,65 in	82 mm 3,23 in		1,68 kg 3,70 lbs	55500 mm ² 86,01 in ²	19-002621